



**CLASS D
MONOBLOCK AMPLIFIER**

DM1500, DM2500

OWNER'S MANUAL

INTRODUCTION



Thank you for purchasing a **DD Audio** amplifier. **DD Audio** amplifiers are painstakingly designed to provide years of high-performance listening pleasure. To achieve optimum performance we suggest you have your amplifier installed by an Authorized **DD Audio** Dealer. It is also highly recommended that you read this Owner's Manual to familiarize yourself with the many features of your amplifier.

The DM Series contains monoblock amplifiers. These amps are engineered specifically for low frequency car audio reinforcement. Designed with the goal of being the best amps on the market for everyone from the everyday enthusiast to the hardcore competitor. The DM Series will be the soul of your audio system delivering clean, powerful audio. These amps feature compact chassis, strong power, logical controls and efficient design. No shortcuts were taken when deciding on the internal components and feature sets. Our engineers paid extremely close attention to every stage of the DM Series circuit design; and utilized high speed controller chipsets, efficient power devices, precise thermal management and the latest in IC technology. We hope you enjoy using this **DD Audio** product, and if you have any questions regarding setup or installation, please contact the **DD Audio** technical support team.

WARNING

DD Audio amps are built to play at high volumes beyond what your ears can safely handle for extended periods of time. Prolonged exposure to excessively high volume can cause permanent damage to your hearing.



In addition, operation of a motor vehicle while listening to audio equipment at high volume levels may impair your ability to hear external sounds such as: horns, warning signals, or emergency vehicles; thus, constituting to a potential traffic hazard. You may also find your state has laws governing the volume of an audio system in a car. Please be aware of all local and state laws in your area. So, be smart, and behave yourself... As much as possible.

DM1500 & DM2500 SERIES DESIGN FEATURES:

- **MOSFET POWER SUPPLY AMPLIFIER**
- **0 GAUGE POWER TERMINALS**
- **10 GAUGE SPEAKER LEAD TERMINALS**
- **DOUBLE SIDED THROUGH HOLE PCB**
- **VARIABLE 24dB/oct. CROSSOVERS**
- **STRAPPABLE CONNECTION**
- **REMOTE SUBWOOFER CONTROL: DASH MOUNT CONTROL WHICH ALLOWS CONVENIENT LEVEL CONTROL, MONITORING OF BATTERY VOLTAGE, AND CLIPPING INDICATOR**
- **6-WAY PROTECTION: CLIPPING LIMITER, SPEAKER SHORT, THERMAL, OVERLOAD, HI/LOW VOLTAGE, DC OFFSET**
- **12~16V WORKING VOLTAGE**

TECHNICAL SPECIFICATIONS

	DM1500	DM2500
Test Voltage 14.4V		
Channels	1	1
Continuous Wattage		
4Ohm	581	813
2Ohm	1006	1413
1Ohm	1583	2503
Dynamic Wattage	2300	3000
Maximum Current Draw	230A	300A
Frequency Response	15~200Hz	15~200Hz
S/N Ratio	>85dB	>85dB
Damping Factor	>150	>150
RCA Input Voltage Sensitivity	4V - 0.1V	4V - 0.1V
Remote Subwoofer Control	Y	Y
Power Wire Gauge In	0	0
Speaker Wire Gauge Out	10	10
Dimensions: in	13.5x7x2	18x7x2
Dimensions: mm	340x175x55	450x175x55

CONTROL AND CONNECTION FOR DM SERIES AMPLIFIERS

PRE-AMP PANEL

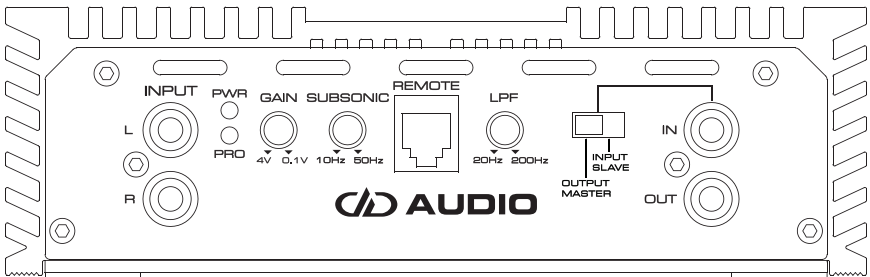

INPUT:

Used for connecting RCA preamp signal cables from the source unit to the amplifier.

PWR LED:

Indicates the amplifier is grounded, and receiving +12V and REM power.

PRO LED:

Indicates a general malfunction due to speaker short, faulty connection or thermal protection.

GAIN:

Matches the output voltage of the source signal to the amplifier's input section.

SUBSONIC:

Controls the high pass cutoff point for the speaker outputs. This helps to eliminate extremely low frequencies that can waste amplifier power and cause damage to your subwoofers.

REMOTE:

This port is for connecting the remote subwoofer control.

LPF:

Controls the low pass cutoff point for the speaker outputs.

OUTPUT MASTER/ INPUT SLAVE:

This switch enables the STRAP or LINK function when connecting two or more DM SERIES amplifiers.

IN:

Used when Strapping or Linking DM Series amplifiers. Connects to the OUT RCA terminal.

OUT:

Used when Strapping two DM SERIES amplifiers. Connects to the IN RCA terminal.

CONTROL AND CONNECTION FOR DM SERIES AMPLIFIERS

POWER PANEL

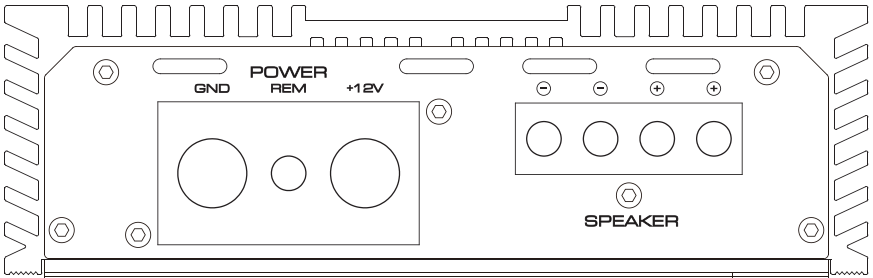

GND:

Connect to a ground wire going directly to the chassis of your vehicle. Minimum cable size is 0 gauge.

REM:

Connect to a switched +12V cable.

+12V:

Connect to a fused positive cable (+12V) from the battery. Minimum power cable size is 0 gauge.

SPEAKER OUTPUT TERMINALS:

Connect to the speaker's + and - terminals. Minimum suggested speaker cable size is 12~10 gauge. DM Series amplifiers have two + and two - terminals for easier connection of multiple speaker cables. Minimum impedance is 1 ohm.

STRAP MODE CONNECTION

Strap Mode allows the connection of two pieces of the same DM SERIES amplifier. In STRAP Mode the MASTER amplifier's pre-amp settings will control the audio signal for both amplifiers. The outputs of both amps will work as a single output section. The minimum speaker impedance in STRAP mode should be 20Ohm. Please follow the instructions and diagram carefully for the correct connection method.

1. Connect the master amplifier to the head-unit and set its OUTPUT MASTER/INPUT SLAVE switch to the OUTPUT MASTER position.
2. Set the SLAVE amplifier's OUTPUT MASTER/INPUT SLAVE switch to the INPUT SLAVE position.
3. Connect the MASTER and SLAVE amplifiers via the IN and OUT RCA jacks as shown in the diagram.
4. Connect SPEAKER terminal (+) of MASTER amplifier to subwoofer (+) lead wire.
5. Connect SPEAKER terminal (+) on SLAVE amplifier to subwoofer (-) lead wire.
6. Connect SPEAKER terminal (-) on MASTER amplifier to SPEAKER terminal (-) on SLAVE amplifier.

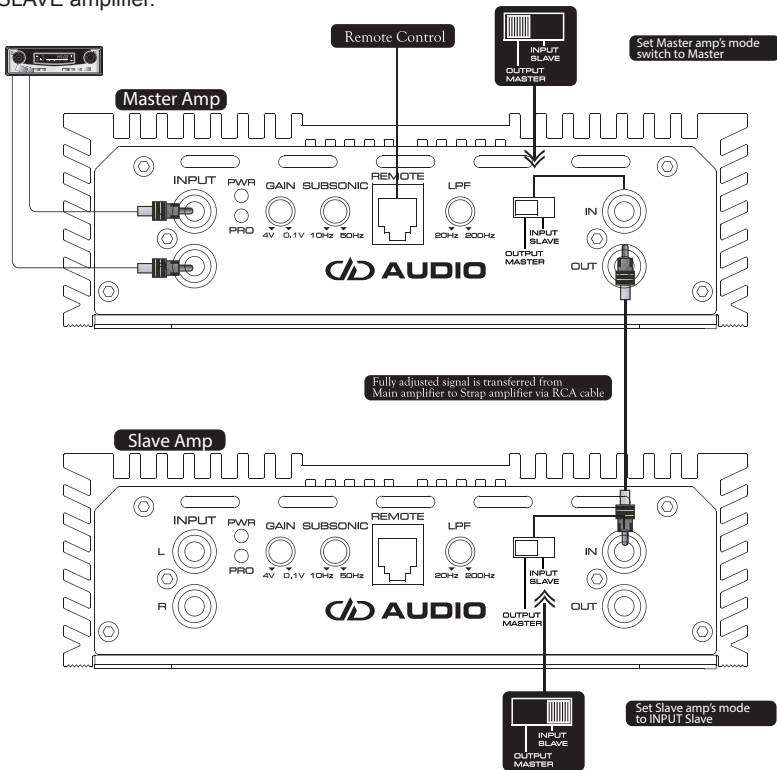

STRAP MODE CONNECTION (Continued)

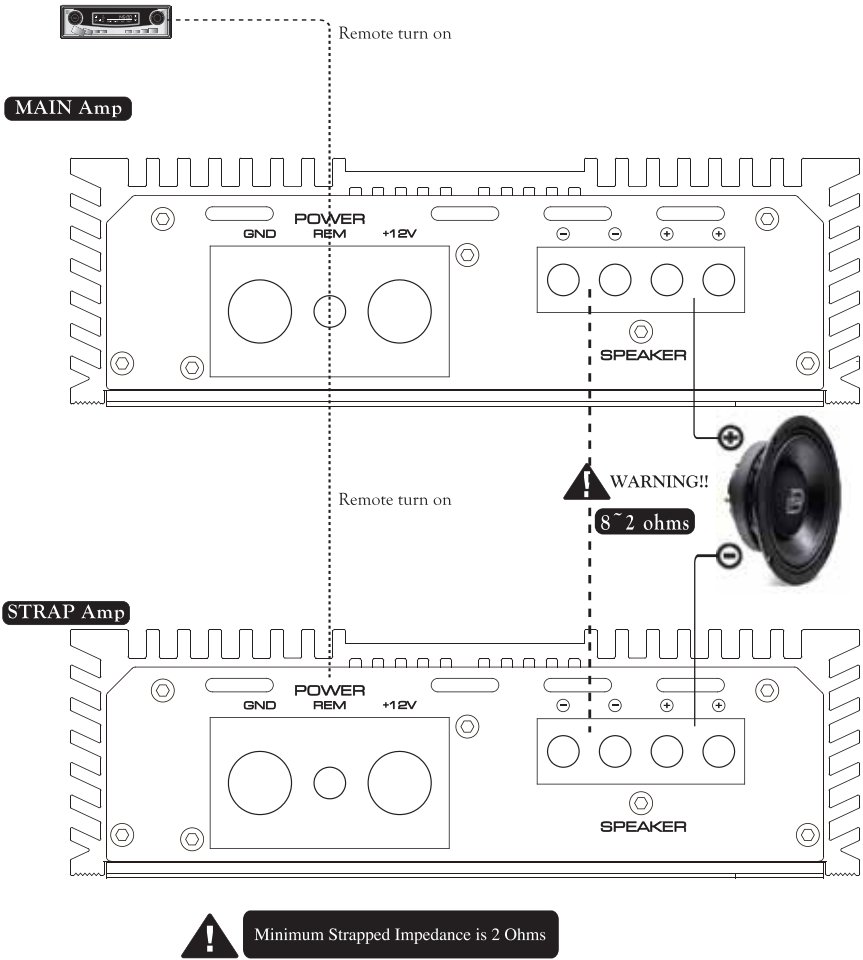

MOUNTING YOUR AMPLIFIER

- Mount your amplifier in a dry, well-ventilated environment.
- Before mounting the amplifier be sure the mounting location and screw placement will not present a hazard to any cables, wiring, fuel lines, fuel tanks, hydraulic lines or other vehicle systems or components.
- Securely mount the amplifier using appropriate hardware so that it does not come loose in the event of a collision or a sudden jolt to the vehicle.
- Do not mount the amplifier to any area that may have excessive vibration (like the subwoofer box).
- Take into consideration your vehicle's safety equipment (air bags, seat belt systems, ABS brake systems, etc.) and avoid interfering with such equipment.

POWERING YOUR AMPLIFIER

Make sure your vehicle's charging system is adequate for the amplifier you're installing. Amplifiers don't make power, they simply convert the current and voltage you give them into wattage. If your charging system is insufficient, your amp will not produce its full rated output. If the current or voltage supply drops too low, even for milliseconds, damage can be caused resulting in amplifier failure. This type of failure is not considered a manufacturer's defect. The addition of even a small amplifier will increase the demand on your charging system. If you are unsure or have questions about your charging system, have it tested by a professional technician to determine its capability.



INSTALLATION

1. Disconnect the negative cable from the car battery.
2. Due to the power requirements of the Amplifier, the +12V connection should be made directly to the positive (+) terminal of battery. For safety measures, install an in-line fuse holder (not included) as close to the battery's positive (+) terminal as possible . The fuse ampere rating should not exceed the total value of the amplifier's rated maximum current draw. If the fuse is further than 18 inches (wire length) from the battery you should re-evaluate the wire and fuse placement.

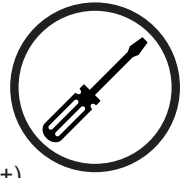

Run the power wire from the battery to the amplifier. To avoid a potential short to the body and a possible fire, this cable should never be ran outside of the vehicle. You will also need to make sure no trim screws or sharp body metal will penetrate the power cable shielding. Don't install the fuse yet. This will be the last thing you do.

3. Connect the ground wire directly to the chassis of your vehicle. The grounding location should be made on metal as close to the amplifier as possible. Remove all paint, sound deadener, etc. from the area of grounding connection. Do not use seat belt bolts for grounding. It is advisable to test the ground with an ohmmeter. Test between the grounding point and the negative battery cable to insure a good low resistance connection (<0.5 Ohm).
4. Run the REM Turn-On wire from the an ignition controlled +12V source. This will turn "ON" the amplifier remotely when the vehicle's stereo is turned "ON".
NOTE IF YOUR RADIO DOES NOT HAVE A +12 VOLT OUTPUT LEAD WHEN THE RADIO IS TURNED ON, THE AMPLIFIER CAN BE CONNECTED TO AN ACCESSORY CIRCUIT IN THE VEHICLE THAT IS LIVE WHEN THE KEY IS "ON".
5. Run the RCA cables if they will be used for the application or make your high-level signal connections.
5. Run the speaker wire to the speakers. It is advised that you leave some extra wire at this point. You can "clean it up" later.
6. Connect the power and ground to the amplifier. Make sure the polarity (+ and -) is correct to avoid damaging the amplifier. Only after this step should you install the fuse at the battery.
7. Connect the remote wire from the head unit to the amplifier. At this time you should turn on the amp and make sure it turns on properly and does not go into protect.

INSTALLATION *(continued)*

8. Turn the amp off and connect the speaker wire to the amp. Pay attention to the polarity (+ and-). If hooked up incorrectly it can cause poor sound due to phasing issues.
9. Connect the RCA cables or high-level harness to the amp.
10. Double check the amplifier controls to verify they are set correctly for your system.
11. Now you can turn on the system and begin the fine tuning process. Turn the amp gain all the way down. Turn the head unit volume to somewhere around 75%.
12. Now you can tune the amp. Take your time and make only one adjustment at a time. It may take some time to get the system fully adjusted. During this time the amp is drawing current from the battery. You should check the battery voltage from time to time and re-charge it if it gets low. Battery voltage can affect the way the amplifier performs.
13. You may have to do some slight re-tuning at a later date if you are installing new speakers at the same time as the amp due to the speakers breaking in.

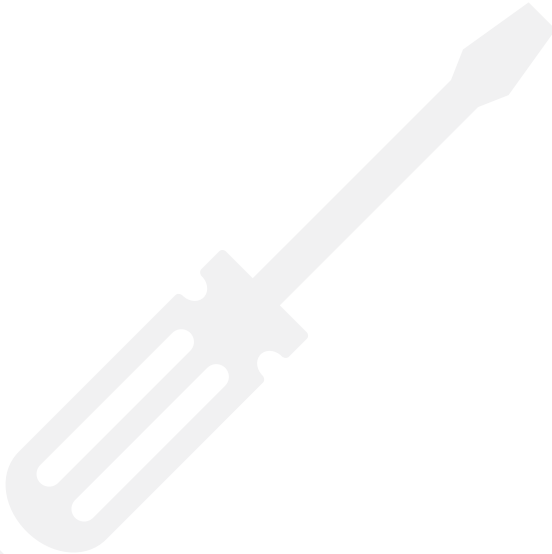

TROUBLESHOOTING:

NO POWER

- Check GND connection.
- Check voltage at the amplifier's +12V and REM terminals.
- Check fuses.

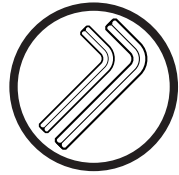

NO SOUND (NO OUTPUT)

- Check all cable routing for shorts or faulty connections,
- Check speakers to verify they are in proper operating condition.
- Check all amplifier controls to ensure they are set properly.
(Gain, Crossovers, Master/Slave Switch)

PROTECTION

- Possible causes overheat (thermal), short.
- If the amplifier shuts down due to overheating, it will automatically return to normal. operation once the amplifier temperature drops below the thermal shutoff temperature. Make sure there is proper airflow with no obstructions around the amplifier to avoid further.
- Thermal protection. In some cases an external fan may be required to keep the amplifier temperature below the thermal protect level.
- The DM-Series working voltage is 9V - 16V. When voltage is lower than 8.5V or higher than 16V the amplifiers will not operate correctly.

DISTORTION

- Check speaker cables for reverse polarity of one channel.

POOR BASS RESPONSE

- Check speaker cables for reverse polarity of one channel.

TROUBLESHOOTING *(continued)*:

BUZZING SOUND

- Check the amplifier and headunit ground connections.
- Check RCA cable connections and possibly replace RCA cables with better noise shielded cable or reroute RCA cables away from power cables.

WHINING NOISE

- Engine noise can be caused by poor grounding of amplifiers, headunits, signal processors, battery or alternator. If you can remove the signal cables from the amplifier and the noise goes away the sound is not being generated by your amplifier, but by an external grounding issue.

If you have any questions regarding setup, installation or warranty please contact the DD Audio technical support team by email at service@ddaudio.com or by phone at **(405) 239-2800**.



DD
AUDIO

DD AUDIO TRUE TO THE SOURCE

4025 NW 36th St., Oklahoma City, OK 73112 • (405) 239-2800

DDAUDIO.COM



|



[YouTube](#)

|

